

GRP backing flanges made of Polyester resin.

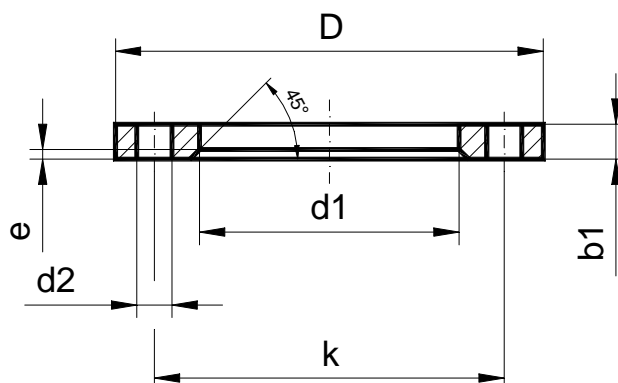

Flange connecting dimensions according to DIN 2501 Part 1, PN10

DN [mm]	D [mm]	k [mm]	d1 [mm]	d2 [mm]	e [mm]	Number of drills	Bolts size	maximum allowable working pressure	
								b1 [mm]	PN [bar]
25	115	85	50,5	14	3,5	4	M12	14	16
32	140	100	58,5	18	3,5	4	M16	15	16
40	150	110	68,5	18	3,5	4	M16	16	16
50	165	125	82,5	18	3,5	4	M16	18	16
65	185	145	95,5	18	3,5	4	M16	20	10
80	200	160	111,5	18	3,5	8	M16	22	10
100	220	180	133,5	18	4,5	8	M16	24	10
125	250	210	160,5	18	4,5	8	M16	27	10
150	285	240	188,5	22	4,5	8	M20	30	10
200	340	295	238	22	6	8	M20	32	6
250	395	350	294	22	6	12	M20	34	6
300	445	400	344	22	6	12	M20	36	6
350	505	460	388	22	7	16	M20	38	4
400	565	515	442	26	7	16	M24	42	4
500	670	620	545	26	7	20	M24	47	4

GRP backing flanges made of Polyester resin.

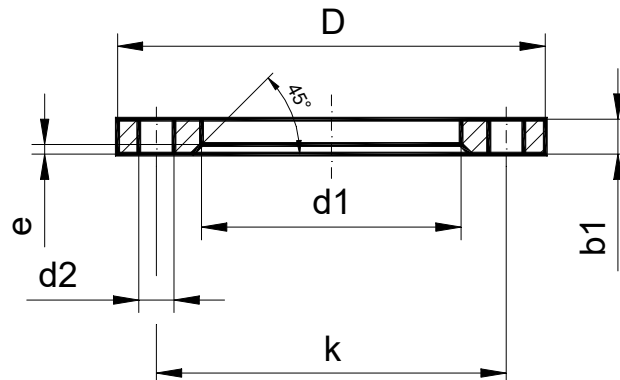

Flange connecting dimensions according to DIN 2501 Part 1, PN10
Nominal pressure PN 10

								maximum allowable working pressure	
DN [mm]	D [mm]	k [mm]	d1 [mm]	d2 [mm]	e [mm]	Number of drills	Bolts size	b1 [mm]	PN [bar]
25	115	85	50,5	14	3,5	4	M12	14	16
32	140	100	58,5	18	3,5	4	M16	15	16
40	150	110	68,5	18	3,5	4	M16	16	16
50	165	125	82,5	18	3,5	4	M16	18	16
65	185	145	95,5	18	3,5	4	M16	20	10
80	200	160	111,5	18	3,5	8	M16	22	10
100	220	180	133,5	18	4,5	8	M16	24	10
125	250	210	160,5	18	4,5	8	M16	27	10
150	285	240	188,5	22	4,5	8	M20	33	10
200	340	295	238	22	6	8	M20	41	10
250	395	350	294	22	6	12	M20	51	10
300	445	400	344	22	6	12	M20	59	10
350	505	460	388	22	7	16	M20	63	10
400	565	515	442	26	7	16	M24	72	10

The grey marked values are different to 1310-WN-en.

Backing flanges made of steel S235JR (St37-2).

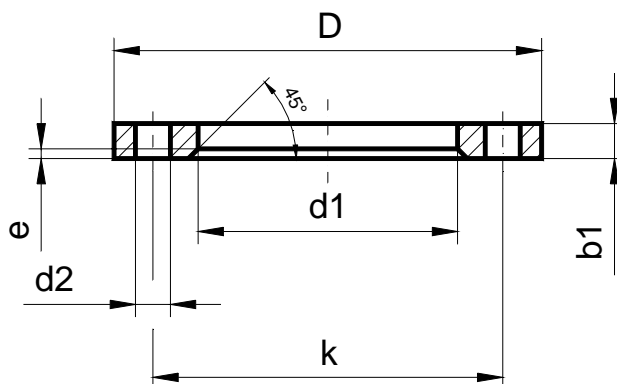

The standard corrosion protection is hot dip galvanized.
Other corrosion protection by request.

							PN	10
								[bar]
DN	D	k	d1	d2	e	Number of drills	Screw metric	b1
[mm]	[mm]	[mm]	[mm]	[mm]	[mm]			[mm]
25	115	85	50,5	14	3	4	M 12	16
32	140	100	58,5	18	3	4	M 16	18
40	150	110	68,5	18	3	4	M 16	18
50	165	125	82,5	18	3	4	M 16	20
65	185	145	95,5	18	3	4 / 8*	M 16	20
80	200	160	111,5	18	3	8	M 16	20
100	220	180	133,5	18	3	8	M 16	22
125	250	210	160,5	18	3	8	M 16	22
150	285	240	188,5	22	3	8	M 20	24
200	340	295	238	22	4	8	M 20	24**
250	395	350	294	22	4	12	M 20	26**
300	445	400	344	22	4	12	M 20	26
350	505	460	388	22	4	16	M 20	30
400	565	515	442	26	4	16	M 24	32
450	615	565	500	26	4	20	M 24	36
500	670	620	545	26	4	20	M 24	38
600	780	725	650	30	4	20	M 27	42**
712	895	840	765	30	4	24	M 27	50**
800	1015	950	860	33	4	24	M 30	56**
900	1115	1050	962	33	4	28	M 30	62**
1000	1230	1160	1062	36	4	28	M 33	70**

* Steel flanges with 4 holes are needed, these can be delivered according to agreement between manufacturer and purchaser.

** Thickness (b1) is different than DIN Standard 16966 part 6

Backing flanges made of steel S235JR (St37-2).

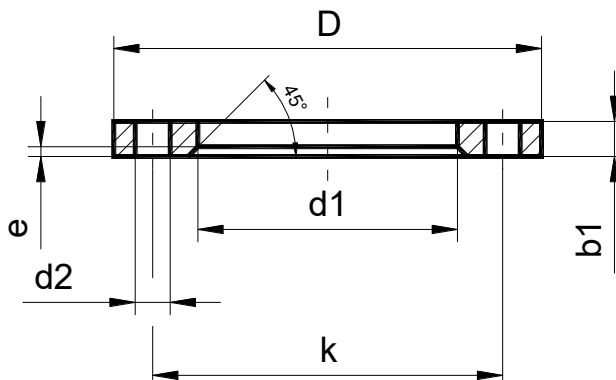

The standard corrosion protection is hot dip galvanized.
Other corrosion protection by request.

DN25 – DN150 / PN16 corresponds 1320-WN

DN25 – DN150 / PN16 corresponds 1320-WN							PN	16
DN	D	k	d1	d2	e	Number of drills	Screw metric	b1 [bar]
[mm]	[mm]	[mm]	[mm]	[mm]	[mm]			[mm]
200	340	295	238	22	4	12	M 20	26
250	405	355	294	26	4	12	M 24	29
300	460	410	352	26	4	12	M 24	32
350	520	470	396	26	4	16	M 24	35
400	580	525	450	30	4	16	M 27	38
450	640	585	510	30	4	20	M 27	42
500	715	650	570	33	4	20	M 30	46
600	840	770	670	36	4	20	M33	55

Attention!
From DN 300 onwards, dimension d1 / PN16 differs from d1 / PN10.

Backing flanges made of steel ASTMA 105.

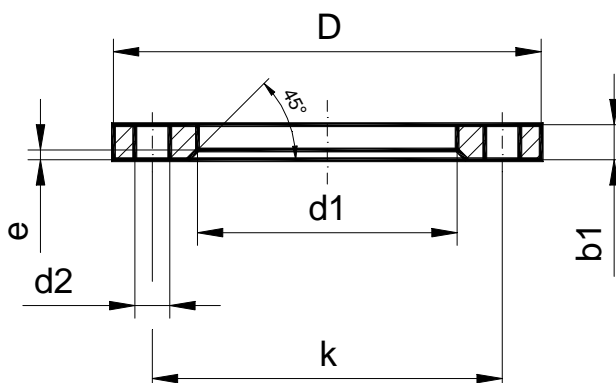

The standard corrosion protection is hot dip galvanized.
Other corrosion protection by request.

Flange connecting dimensions up to 24": according ANSI B16,5 - 150 lbs
>24" according to BS 3293-1960

DN [Inch]	D [mm]	k [mm]	d1 [mm]	d2 [mm]	e [mm]	Number of drills	PN Screw Inch	150 [lbs] b1 [mm]
1"	108	79,4	50,5	16	3	4	1/2"	14
1 1/4"	117	88,9	58,5	16	3	4	1/2"	16
1 1/2"	127	98,4	68,5	16	3	4	1/2"	18
2"	152	120,6	82,5	19	3	4	5/8"	19
2 1/2"	178	139,7	95,5	19	3	4	5/8"	22
3"	190	152,4	111,5	19	3	4	5/8"	24
4"	229	190,5	133,5	19	3	8	5/8"	24
5"	254	216	160,5	22,5	3	8	3/4"	24
6"	279	241,3	188,5	22,5	3	8	3/4"	25
8"	343	298,4	238	22,5	4	8	3/4"	29
10"	406	362	294	25,5	4	12	7/8"	30
12"	483	431,8	344	25,5	4	12	7/8"	32
14"	533	476,2	388	29	4	12	1"	35
16"	597	539,7	442	29	4	16	1"	37
18"	635	577,8	500	32	4	16	1 1/8"	40
20"	698	635	545	32	4	20	1 1/8"	43
22"	749	692	600	35	4	20	1 1/4"	46
24"	813	749	650	35	4	20	1 1/4"	48
28"	927	864	765	35	4	28	1 1/4"	52
32"	1060	978	860	41,5	4	28	1 1/2"	57
36"	1168	1086	962	41,5	4	32	1 1/2"	60
40"	1289	1200	1062	41,5	4	36	1 1/2"	63
42"	1346	1257	1120	41,5	4	36	1 1/2"	67

The following boundary conditions were checked to determine the laminate dimensions:

- Shear stress verification
- Proof of the root condition
- Length/wall thickness ratio

Wall thickness S4 [mm] according to 2101-WN-en Pipeline Type K / 4110-WN-en – 4150-WN-en Pipeline Type BK.

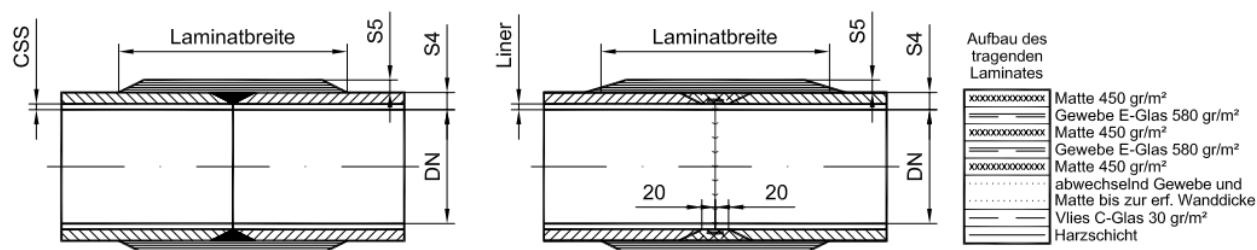

Laminatdicke S5 [mm]					PN2,5-10 [bar]		PN16 [bar]
DN [mm]	PN2,5 [bar]	PN6 [bar]	PN10 [bar]	PN16 [bar]	DN [mm]	Laminatbreite	
				[mm]		[mm]	
25	3,5	3,5	3,5	3,5	25	140	140
32	3,5	3,5	3,5	3,5	32	140	140
40	3,5	3,5	3,5	3,5	40	140	140
50	3,5	3,5	3,5	3,5	50	140	140
65	3,5	3,5	3,5	3,5	65	140	140
80	3,5	3,5	3,5	3,5	80	140	140
100	3,5	3,5	3,5	4,0	100	140	180
125	3,5	3,5	3,5	4,9	125	140	200
150	3,5	3,6	3,5	5,9	150	180	220
200	3,5	4,7	4,6	7,7	200	180	280
250	3,5	5,8	5,7	9,5	250	220	340
300	3,5	6,9	6,8	11,3	300	260	380
350	3,5	8,0	7,8	13,1	350	300	440
400	3,5	5,2	8,9	14,9	400	340	480
500	3,5	6,5	11,1	18,6	500	400	600
600	3,5	7,7	13,2	22,2	600	460	720
712	3,7	9,0	15,4		712	540	
800	4,2	10,2	17,6		800	600	
900	4,7	11,5	19,7		900	660	
1000	5,2	12,7	21,9		1000	740	

Above – mentioned dimensions are minimum thickness are lenthths!

Pipe type K

Specific values Epoxy Vinyl Ester Resin Bisphenol-A Base

Tensile strength N/mm ²	165
Tensile elasticity modulus N/mm ²	12500
Bending strength N/mm ²	200
Bending elasticity modulus N/mm ²	11500
A1 I = A 1 B (valid for 2*10 ⁵ h)	1,55
A2	s. DIBt Media list
A3	s. WN 2041
A4	1,0
Density g/cm ³	1,6
Breaking load of laminate connections N/mm ²	165
Thermal conductivity W/mK	0,24
Coefficient of linear expansion	21 x 10 ⁻⁶ x 1/K
Barcol hardness	> 35
Styrene content after heat treatment %	< 2
Thermal load	15 – 18 MJoul/kg
Velocity of sound	2475 m/s

Specific values Epoxy Vinyl Ester Resin Novolac Base

Tensile strength N/mm ²	170
Tensile elasticity modulus N/mm ²	13000
Bending strength N/mm ²	200
Bending elasticity modulus N/mm ²	12000
A1 I = A 1 B (valid for 2*10 ⁵ h)	1,4
A2	s. DIBt Media list
A3	s. WN 2041
A4	1,0
Density g/cm ³	1,6
Breaking load of laminate connections N/mm ²	170
Thermal conductivity W/mK	0,24
Coefficient of linear expansion	21 x 10 ⁻⁶ x 1/K
Barcol hardness	> 35
Styrene content after heat treatment %	< 2

Calculation of wall thickness S4 [mm] according to AD N1.

Applicable for following values:

Corrosion barrier (CSS) = 2,5 mm
 $A \cdot S = 6$
 $\delta = 165 \text{ N/mm}^2$

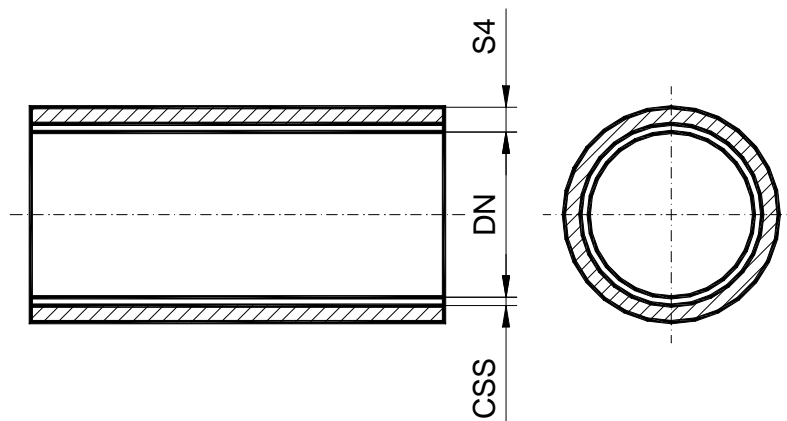

	PN 2,5	PN 4	PN 6	PN 10	PN 16
DN [mm]	S4 [mm]	S4 [mm]	S4 [mm]	S4 [mm]	S4 [mm]
25					5,0
32					5,0
40					5,0
50					5,0
65					5,0
80				5,0	5,2
100				5,0	6,0
125			5,0	5,2	6,6
150			5,0	6,0	7,4
200		5,0	5,2	6,6	8,8
250		5,0	6,0	7,4	10,2
300	5,0	5,2	6,0	8,8	11,6
350	5,0	5,2	6,6	9,4	13,7
400	5,0	6,0	7,4	10,2	15,1
450	5,0	6,0	8,0	11,6	16,5
500	5,2	6,6	8,8	12,2	17,9
600	6,0	7,4	9,4	13,7	
712	6,0	8,0	10,8	15,8	
800	6,6	8,8	11,6	17,9	
900	6,6	9,4	13,0	19,3	
1000	7,4	10,2	13,7	21,5	

Calculation of pressed stub flanges according to EN 13121-3 / 2016. Possible stresses will not be considered. Specific values for calculation are as follows:

$$\begin{aligned} \sigma_B &= 180 \text{ N/mm}^2 & \text{corrosion barrier (CSS)} &= 2,5 \text{ mm} \\ A \cdot S &= 6 \end{aligned}$$

Flange connecting dimensions according to DIN EN 1092-1, PN10
Wall thickness S4 [mm] according to 2101-WN.

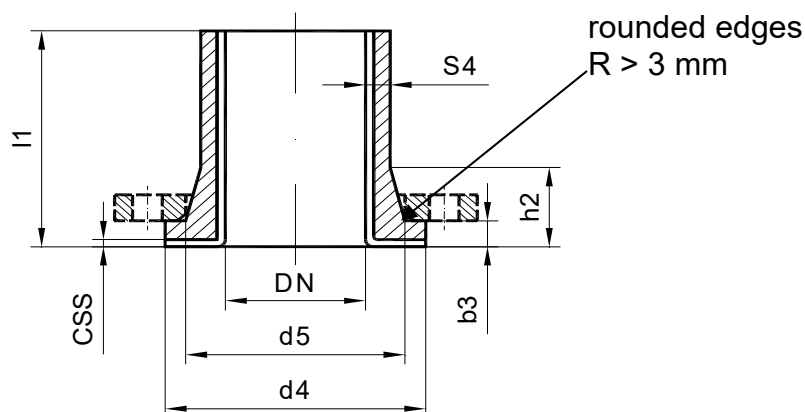

DN [mm]	l ₁ [mm]	d ₄ [mm]	d ₅ [mm]	h ₂ [mm]	b ₃ [mm]	b ₃ [mm]	b ₃ [mm]	b ₃ [mm]
25	150	68	50	30				14,5
32	150	78	58	32				16,5
40	150	88	68	35				16,5
50	150	102	82	40				16,5
65	150	122	95	44				17,5
80	150	138	111	48				18,5
100	150	158	133	55				20,5
125	200	188	160	64				22,5
150	200	212	188	71				24,5
200	200	268	237	85			27,5	
250	300	320	293	101			30,5	
300	300	370	343	116			32,5	
350	450	430	387	133		34,5	45,5	
400	450	482	441	147		37,5	49,5	
450	450	538	499	160		39,5	51,5	
500	450	585	544	178		41,5	61,5	
600	500	685	648	209	42,5	47,5	72,5	
712	500	800	758	243	42,5	51,5	81,5	
800	600	905	858	271	42,5	65,5	96,5	
900	600	1005	960	302	42,5	74,5	108,5	
1000	600	1110	1060	332	42,5	88,5	122,5	

Calculation of full faced flanges according to EN 13121-3 / 2016. Possible stresses will not be considered. Specific values for calculation are as follows:

σ_B = 180 N/mm² corrosion barrier (CSS) = 2,5 mm
A·S = 6

Flange connecting dimensions according to DIN EN 1092-1, PN10
Wall thickness S4 [mm] according to 2101-WN.

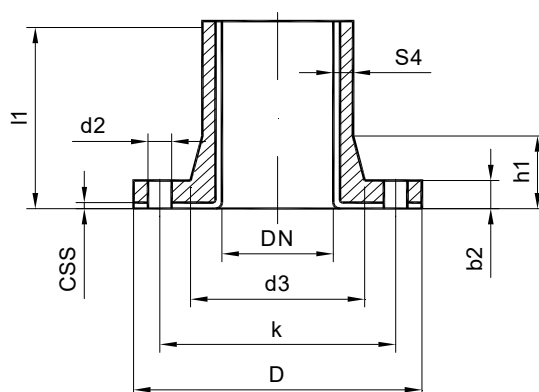

DN [mm]	l_1 [mm]	D [mm]	d_3 [mm]	d_2 [mm]	k [mm]	h_1 [mm]	PN 2,5	PN 6	PN 10	PN 16
							b_2 [mm]	b_2 [mm]	b_2 [mm]	b_2 [mm]
25	150	115	50	14	85	30				16,5
32	150	140	58	18	100	32				16,5
40	150	150	68	18	110	35				16,5
50	150	165	82	18	125	40				16,5
65	150	185	95	18	145	44				18,5
80	150	200	111	18	160	48				20,5
100	150	220	133	18	180	55			18,5	22,5
125	200	250	160	18	210	64			20,5	27,5
150	200	285	188	22	240	71		20,5	23,5	32,5
200	200	340	245	22	295	85		20,5	27,5	
250	300	395	300	22	350	101		24,5	32,5	
300	300	445	350	22	400	116		28,5	40,5	
350	450	505	410	22	460	133		32,5	40,5	
400	450	565	460	26	515	147		35,5	50,5	
450	450	615	511	26	565	120		39,5	55,5	
500	450	670	565	26	620	178		43,5	61,5	
600	500	780	660	30	725	132	43,5	58,5	82,5	
712	500	895	780	30	840	146	43,5	49,5	85,5	
800	600	1015	875	33	950	168	43,5	73,5	106,5	
900	600	1115	980	33	1050	178	43,5	80,5	117,5	
1000	600	1230	1080	36	1160	194	43,5	95,5	134,5	

The calculation of wall thickness according to AD 2000 N1 with a safety factor of $AxS=6$.

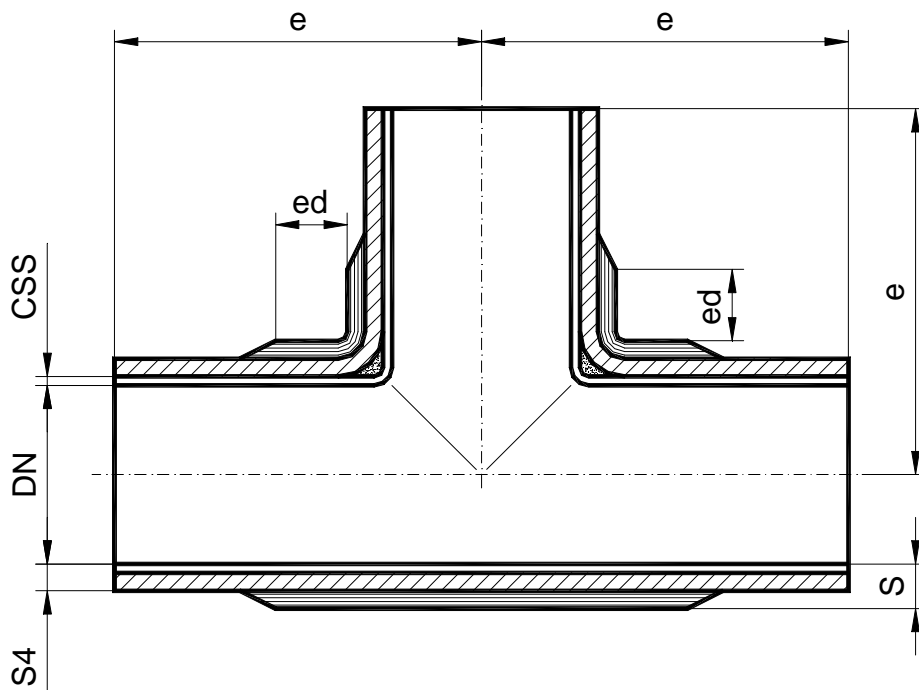

PN	2,5		4		6		10		16			
	S4 [mm]	S [mm]	S4 [mm]	S [mm]	S4 [mm]	S [mm]	S4 [mm]	S [mm]	S4 [mm]	S [mm]	e [mm]	ed [mm]
25					5,0	5,0	5,0	5,0	5,0	5,2	110	50
32					5,0	5,0	5,0	5,2	5,0	6,0	130	50
40			5,0	5,0	5,0	5,0	5,0	5,2	5,0	6,0	150	50
50			5,0	5,0	5,0	5,2	5,0	6,0	5,0	7,4	180	50
65			5,0	5,0	5,0	5,2	5,0	6,6	5,0	8,8	140	50
80			5,0	5,2	5,0	6,0	5,0	7,4	5,2	10,2	165	50
100	5,0	5,0	5,0	6,0	5,0	6,6	5,0	8,8	6,0	11,6	205	50
125	5,0	5,2	5,0	6,6	5,0	7,4	5,2	10,2	6,6	13,7	245	60
150	5,0	6,0	5,0	7,4	5,0	8,8	6,0	11,6	7,4	15,9	285	70
200	5,0	6,6	5,0	8,8	5,2	10,2	6,6	14,5	8,8	20,1	365	80
250	5,0	7,4	5,0	9,4	6,0	12,2	7,4	17,3	10,2	23,6	450	100
300	5,0	8,8	5,2	10,8	6,0	14,5	8,8	20,1	11,6	27,8	525	100
350	5,0	9,4	5,2	12,2	6,6	15,9	9,4	23,0	13,7	32,1	600	120
400	5,0	10,2	6,0	13,7	7,4	17,9	10,2	25,8	15,1	36,3	680	120

The calculation of wall thickness according to AD 2000 N1 with a safety factor of $AxS=6$.

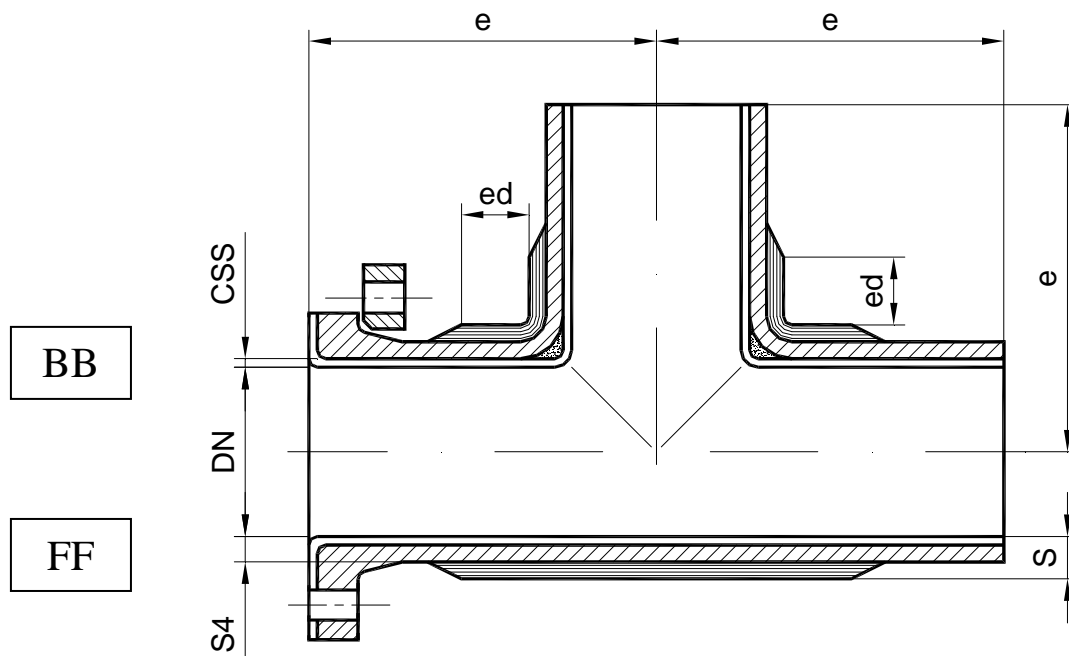

PN	2,5		4		6		10		16		e [mm]	ed [mm]
	S4 [mm]	S [mm]	S4 [mm]	S [mm]	S4 [mm]	S [mm]	S4 [mm]	S [mm]	S4 [mm]	S [mm]		
25					5,0	5,0	5,0	5,0	5,0	5,2	110	50
32					5,0	5,0	5,0	5,2	5,0	6,0	130	50
40			5,0	5,0	5,0	5,0	5,0	5,2	5,0	6,0	150	50
50			5,0	5,0	5,0	5,2	5,0	6,0	5,0	7,4	180	50
65			5,0	5,0	5,0	5,2	5,0	6,6	5,0	8,8	140	50
80			5,0	5,2	5,0	6,0	5,0	7,4	5,2	10,2	165	50
100	5,0	5,0	5,0	6,0	5,0	6,6	5,0	8,8	6,0	11,6	205	50
125	5,0	5,2	5,0	6,6	5,0	7,4	5,2	10,2	6,6	13,7	245	60
150	5,0	6,0	5,0	7,4	5,0	8,8	6,0	11,6	7,4	15,9	285	70
200	5,0	6,6	5,0	8,8	5,2	10,2	6,6	14,5	8,8	20,1	365	80
250	5,0	7,4	5,0	9,4	6,0	12,2	7,4	17,3	10,2	23,6	450	100
300	5,0	8,8	5,2	10,8	6,0	14,5	8,8	20,1	11,6	27,8	525	100
350	5,0	9,4	5,2	12,2	6,6	15,9	9,4	23,0	13,7	32,1	600	120
400	5,0	10,2	6,0	13,7	7,4	17,9	10,2	25,8	15,1	36,3	680	120

The calculation of wall thickness according to AD 2000 N1 with a safety factor of $AxS=6$.

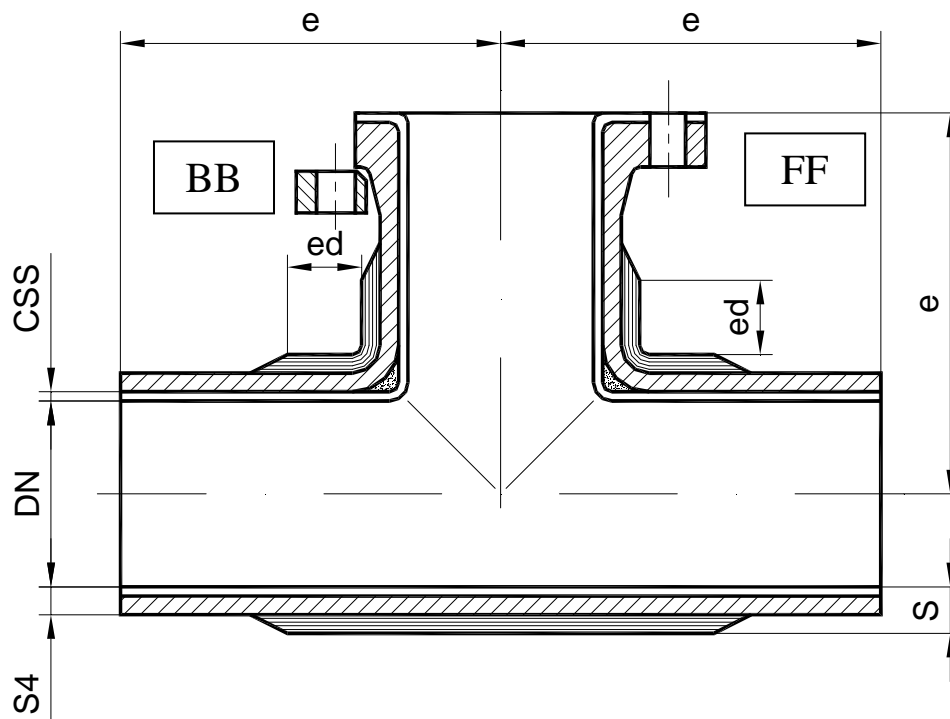

PN	2,5		4		6		10		16		e [mm]	ed [mm]
	S4 [mm]	S [mm]	S4 [mm]	S [mm]	S4 [mm]	S [mm]	S4 [mm]	S [mm]	S4 [mm]	S [mm]		
25					5,0	5,0	5,0	5,0	5,0	5,2	110	50
32					5,0	5,0	5,0	5,2	5,0	6,0	130	50
40			5,0	5,0	5,0	5,0	5,0	5,2	5,0	6,0	150	50
50			5,0	5,0	5,0	5,2	5,0	6,0	5,0	7,4	180	50
65			5,0	5,0	5,0	5,2	5,0	6,6	5,0	8,8	140	50
80			5,0	5,2	5,0	6,0	5,0	7,4	5,2	10,2	165	50
100	5,0	5,0	5,0	6,0	5,0	6,6	5,0	8,8	6,0	11,6	205	50
125	5,0	5,2	5,0	6,6	5,0	7,4	5,2	10,2	6,6	13,7	245	60
150	5,0	6,0	5,0	7,4	5,0	8,8	6,0	11,6	7,4	15,9	285	70
200	5,0	6,6	5,0	8,8	5,2	10,2	6,6	14,5	8,8	20,1	365	80
250	5,0	7,4	5,0	9,4	6,0	12,2	7,4	17,3	10,2	23,6	450	100
300	5,0	8,8	5,2	10,8	6,0	14,5	8,8	20,1	11,6	27,8	525	100
350	5,0	9,4	5,2	12,2	6,6	15,9	9,4	23,0	13,7	32,1	600	120
400	5,0	10,2	6,0	13,7	7,4	17,9	10,2	25,8	15,1	36,3	680	120

The calculation of wall thickness according to AD 2000 N1 with a safety factor of AxS=6.

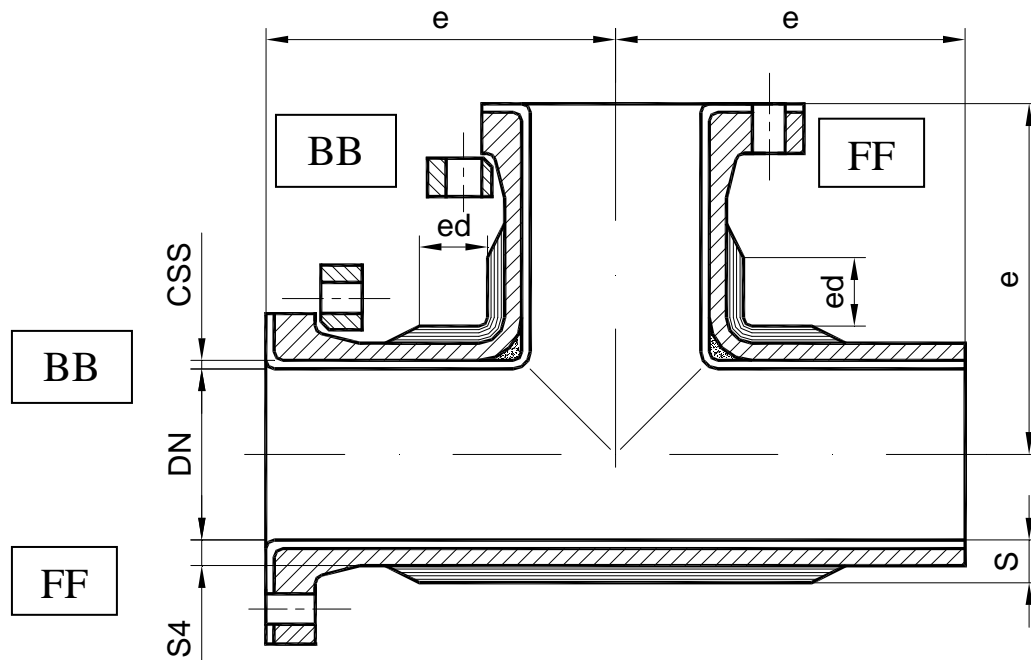

PN	2,5		4		6		10		16		e [mm]	ed [mm]
	S4 [mm]	S [mm]	S4 [mm]	S [mm]	S4 [mm]	S [mm]	S4 [mm]	S [mm]	S4 [mm]	S [mm]		
25					5,0	5,0	5,0	5,2	5,0	6,0	110	50
32					5,0	5,0	5,0	6,0	5,0	7,4	130	50
40			5,0	5,0	5,0	5,2	5,0	6,6	5,0	8,0	150	50
50			5,0	5,0	5,0	6,0	5,0	7,4	5,0	9,4	180	50
65			5,0	5,0	5,0	6,6	5,0	8,0	5,0	10,8	140	50
80			5,0	5,2	5,0	7,4	5,0	9,4	5,2	13,0	165	50
100	5,0	5,0	5,0	6,0	5,0	8,0	5,0	10,8	6,0	15,1	205	50
125	5,0	5,2	5,0	6,6	5,0	8,8	5,2	12,2	6,6	17,3	245	60
150	5,0	6,0	5,0	7,4	5,0	10,2	6,0	14,5	7,4	20,7	285	70
200	5,0	6,6	5,0	8,8	5,2	13,0	6,6	17,9	8,8	25,8	365	80
250	5,0	7,4	5,0	9,4	6,0	15,1	7,4	20,7	10,2	30,7	450	100
300	5,0	8,8	5,2	10,8	6,0	17,9	8,8	25,8	11,6	37,7	525	100
350	5,0	9,4	5,2	12,2	6,6	20,1	9,4	29,2	13,7	42,8	600	120
400	5,0	10,2	6,0	13,7	7,4	22,2	10,2	32,9	15,1	47,7	680	120

The calculation of wall thickness according to AD 2000 N1 with a safety factor of $AxS=6$.

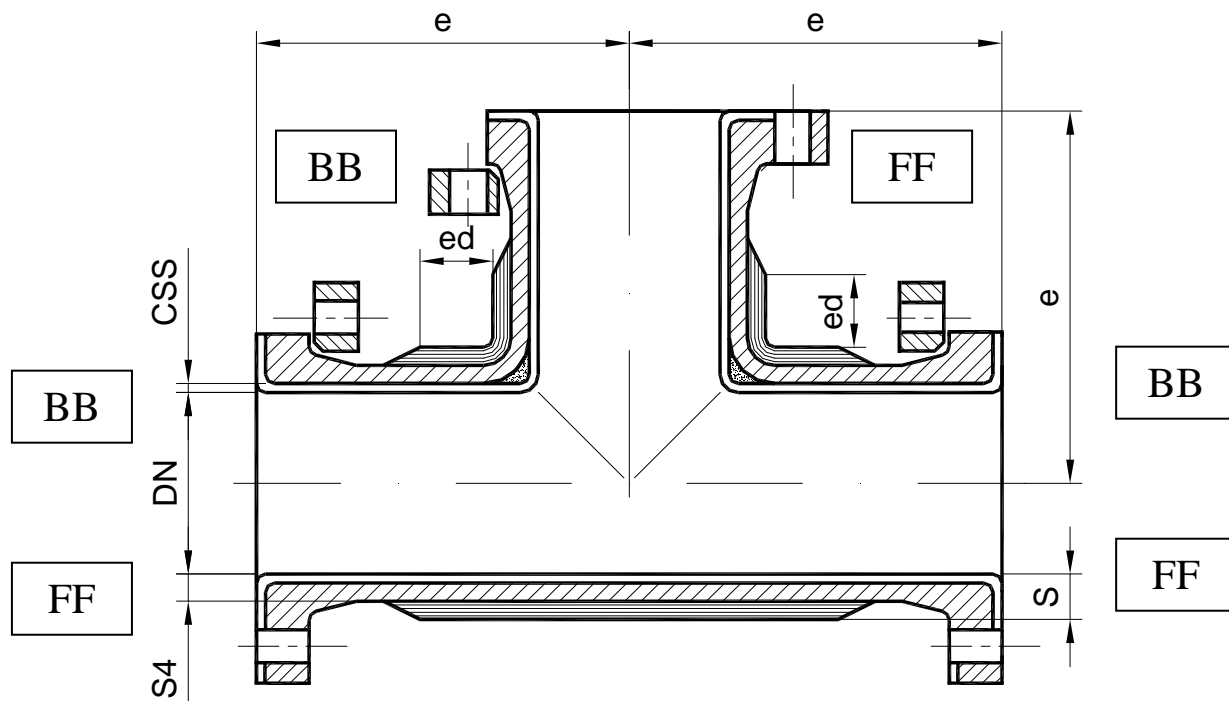

PN	2,5		4		6		10		16		e [mm]	ed [mm]
	S4 [mm]	S [mm]	S4 [mm]	S [mm]	S4 [mm]	S [mm]	S4 [mm]	S [mm]	S4 [mm]	S [mm]		
25					5,0	5,0	5,0	5,0	5,0	5,2	110	50
32					5,0	5,0	5,0	5,2	5,0	6,0	130	50
40			5,0	5,0	5,0	5,0	5,0	5,2	5,0	6,0	150	50
50			5,0	5,0	5,0	5,2	5,0	6,0	5,0	7,4	180	50
65			5,0	5,0	5,0	5,2	5,0	6,6	5,0	8,8	140	50
80			5,0	5,2	5,0	6,0	5,0	7,4	5,2	10,2	165	50
100	5,0	5,0	5,0	6,0	5,0	6,6	5,0	8,8	6,0	11,6	205	50
125	5,0	5,2	5,0	6,6	5,0	7,4	5,2	10,2	6,6	13,7	245	60
150	5,0	6,0	5,0	7,4	5,0	8,8	6,0	11,6	7,4	15,9	285	70
200	5,0	6,6	5,0	8,8	5,2	10,2	6,6	14,5	8,8	20,1	365	80
250	5,0	7,4	5,0	9,4	6,0	12,2	7,4	17,3	10,2	23,6	450	100
300	5,0	8,8	5,2	10,8	6,0	14,5	8,8	20,1	11,6	27,8	525	100
350	5,0	9,4	5,2	12,2	6,6	15,9	9,4	23,0	13,7	32,1	600	120
400	5,0	10,2	6,0	13,7	7,4	17,9	10,2	25,8	15,1	36,3	680	120

The calculation of wall thickness according to AD 2000 N1 with a safety factor of $AxS=6$.

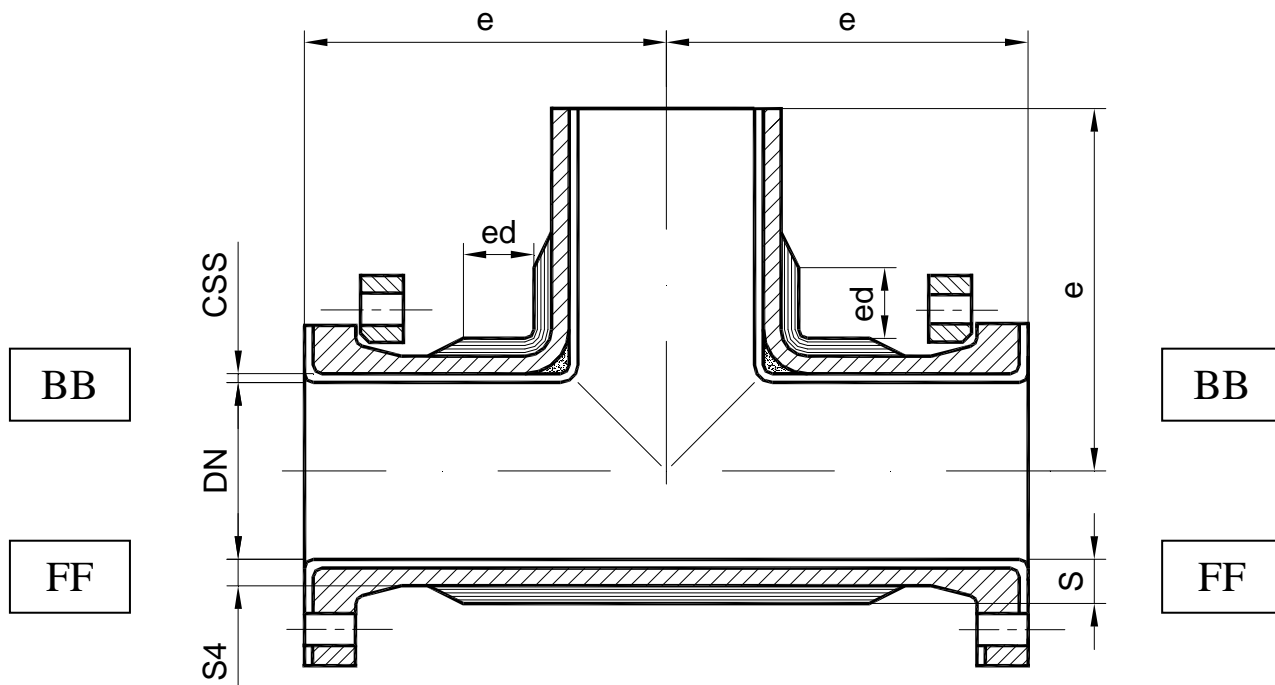

PN	2,5		4		6		10		16		e [mm]	ed [mm]
	S4 [mm]	S [mm]	S4 [mm]	S [mm]	S4 [mm]	S [mm]	S4 [mm]	S [mm]	S4 [mm]	S [mm]		
25					5,0	5,0	5,0	5,0	5,0	5,2	110	50
32					5,0	5,0	5,0	5,2	5,0	6,0	130	50
40			5,0	5,0	5,0	5,0	5,0	5,2	5,0	6,0	150	50
50			5,0	5,0	5,0	5,2	5,0	6,0	5,0	7,4	180	50
65			5,0	5,0	5,0	5,2	5,0	6,6	5,0	8,8	140	50
80			5,0	5,2	5,0	6,0	5,0	7,4	5,2	10,2	165	50
100	5,0	5,0	5,0	6,0	5,0	6,6	5,0	8,8	6,0	11,6	205	50
125	5,0	5,2	5,0	6,6	5,0	7,4	5,2	10,2	6,6	13,7	245	60
150	5,0	6,0	5,0	7,4	5,0	8,8	6,0	11,6	7,4	15,9	285	70
200	5,0	6,6	5,0	8,8	5,2	10,2	6,6	14,5	8,8	20,1	365	80
250	5,0	7,4	5,0	9,4	6,0	12,2	7,4	17,3	10,2	23,6	450	100
300	5,0	8,8	5,2	10,8	6,0	14,5	8,8	20,1	11,6	27,8	525	100
350	5,0	9,4	5,2	12,2	6,6	15,9	9,4	23,0	13,7	32,1	600	120
400	5,0	10,2	6,0	13,7	7,4	17,9	10,2	25,8	15,1	36,3	680	120

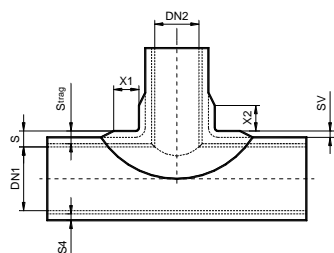

Typ 1

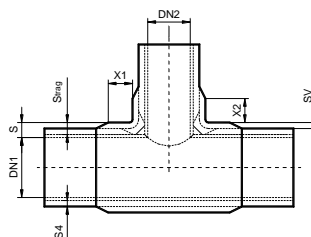

Typ 2

Wall thickness s_4 [mm] according to 2101-WN-en

		Laminate thickness s_v																	
DN 2 [mm]	DN 1 [mm]	25	32	40	50	65	80	100	125	150	200	250	300	350	400	450	500	600	
25	25	2,5	-	-	-	-	-	-	-	-	-	-	-	-	-	-	-	-	-
32	25	2,5	2,5	-	-	-	-	-	-	-	-	-	-	-	-	-	-	-	-
40	25	2,5	2,5	2,5	-	-	-	-	-	-	-	-	-	-	-	-	-	-	-
50	25	2,5	2,5	2,5	2,5	-	-	-	-	-	-	-	-	-	-	-	-	-	-
65	25	2,5	2,5	2,5	2,5	2,5	-	-	-	-	-	-	-	-	-	-	-	-	-
80	25	2,5	2,5	2,5	2,5	2,5	2,5	-	-	-	-	-	-	-	-	-	-	-	-
100	25	2,5	2,5	2,5	2,5	2,5	2,6	2,8	-	-	-	-	-	-	-	-	-	-	-
125	25	2,5	2,5	2,5	2,6	2,8	3,0	3,2	3,4	-	-	-	-	-	-	-	-	-	-
150	25	2,5	2,5	2,6	2,9	3,2	3,4	3,7	3,9	4,1	-	-	-	-	-	-	-	-	-
200	25	2,6	2,8	3,1	3,4	3,7	4,0	4,4	4,7	5,0	5,4	-	-	-	-	-	-	-	-
250	25	2,9	3,2	3,5	3,8	4,2	4,6	5,0	5,4	5,8	6,3	6,7	-	-	-	-	-	-	-
300	25	3,3	3,6	3,9	4,2	4,7	5,1	5,6	6,1	6,5	7,2	7,7	8,1	-	-	-	-	-	-
350	25	3,6	3,9	4,2	4,6	5,1	5,5	6,1	6,6	7,1	7,9	8,5	9,0	9,4	-	-	-	-	-
400	25	3,9	4,2	4,5	4,9	5,5	6,0	6,5	7,2	7,7	8,6	9,3	9,9	10,3	10,7	-	-	-	-
450	25	4,2	4,5	4,9	5,3	5,9	6,4	7,0	7,7	8,3	9,2	10,0	10,7	11,2	11,6	12,0	-	-	-
500	25	4,5	4,8	5,2	5,6	6,2	6,8	7,4	8,1	8,8	9,8	10,7	11,4	12,0	12,5	13,0	13,3	-	-

		Laminate width X1 and X2																	
DN 2 [mm]	DN 1 [mm]	25	32	40	50	65	80	100	125	150	200	250	300	350	400	450	500	600	
25	25	25	-	-	-	-	-	-	-	-	-	-	-	-	-	-	-	-	-
32	25	25	25	-	-	-	-	-	-	-	-	-	-	-	-	-	-	-	-
40	25	25	25	25	-	-	-	-	-	-	-	-	-	-	-	-	-	-	-
50	25	25	25	25	25	-	-	-	-	-	-	-	-	-	-	-	-	-	-
65	25	25	25	25	25	25	-	-	-	-	-	-	-	-	-	-	-	-	-
80	25	25	25	25	25	25	25	-	-	-	-	-	-	-	-	-	-	-	-
100	25	25	25	25	25	25	25	25	-	-	-	-	-	-	-	-	-	-	-
125	25	25	25	25	25	25	25	25	30	-	-	-	-	-	-	-	-	-	-
150	25	30	30	30	30	30	30	30	35	35	-	-	-	-	-	-	-	-	-
200	35	35	35	35	35	40	40	40	40	45	45	-	-	-	-	-	-	-	-
250	40	40	45	45	45	45	50	50	50	50	50	50	-	-	-	-	-	-	-
300	50	50	50	50	50	55	55	55	60	60	60	60	60	-	-	-	-	-	-
350	55	55	55	60	60	60	65	65	65	70	70	70	70	70	-	-	-	-	-
400	60	60	65	65	65	70	70	70	75	75	80	80	80	80	80	-	-	-	-
450	70	70	70	70	75	75	75	80	80	85	85	85	90	90	90	90	-	-	-
500	75	75	75	80	80	80	85	85	90	90	95	95	95	100	100	100	100	-	-

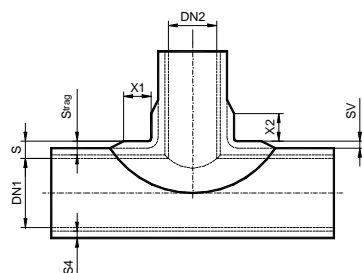

Typ 1

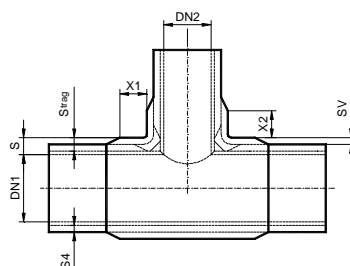

Typ 2

Wall thickness s_4 [mm] according to 2101-WN-en

Laminate thickness s_v																
DN 2 [mm] \ DN 1 [mm]	25	32	40	50	65	80	100	125	150	200	250	300	350	400	450	500
25	2,5	-	-	-	-	-	-	-	-	-	-	-	-	-	-	-
32	2,5	2,5	-	-	-	-	-	-	-	-	-	-	-	-	-	-
40	2,5	2,5	2,5	-	-	-	-	-	-	-	-	-	-	-	-	-
50	2,5	2,5	2,5	2,5	-	-	-	-	-	-	-	-	-	-	-	-
65	2,5	2,5	2,5	2,5	2,6	-	-	-	-	-	-	-	-	-	-	-
80	2,5	2,5	2,7	2,8	3,1	3,2	-	-	-	-	-	-	-	-	-	-
100	2,6	2,8	3,0	3,3	3,5	3,8	4,0	-	-	-	-	-	-	-	-	-
125	2,9	3,2	3,5	3,7	4,1	4,4	4,6	4,9	-	-	-	-	-	-	-	-
150	3,3	3,6	3,8	4,2	4,6	4,9	5,3	5,6	5,9	-	-	-	-	-	-	-
200	3,9	4,2	4,5	4,9	5,4	5,8	6,3	6,8	7,2	7,7	-	-	-	-	-	-
250	4,4	4,8	5,2	5,6	6,2	6,7	7,3	7,8	8,3	9,1	9,6	-	-	-	-	-
300	4,9	5,3	5,8	6,2	6,9	7,4	8,1	8,8	9,4	10,3	11,0	11,5	-	-	-	-
350	5,5	5,9	6,3	6,8	7,5	8,1	8,9	9,7	10,3	11,4	12,2	12,9	13,4	-	-	-
400	6,0	6,4	6,9	7,4	8,1	8,8	9,6	10,5	11,2	12,4	13,4	14,2	14,8	15,3	-	-
450	6,4	6,9	7,4	7,9	8,7	9,4	10,3	11,2	12,0	13,4	14,5	15,3	16,1	16,7	17,2	-
500	6,9	7,4	7,9	8,5	9,3	10,0	10,9	11,9	12,8	14,3	15,5	16,5	17,3	18,0	18,6	19,1

Laminate width X1 and X2																
DN 2 [mm] \ DN 1 [mm]	25	32	40	50	65	80	100	125	150	200	250	300	350	400	450	500
25	25	-	-	-	-	-	-	-	-	-	-	-	-	-	-	-
32	25	25	-	-	-	-	-	-	-	-	-	-	-	-	-	-
40	25	25	25	-	-	-	-	-	-	-	-	-	-	-	-	-
50	25	25	25	25	-	-	-	-	-	-	-	-	-	-	-	-
65	25	25	25	25	25	-	-	-	-	-	-	-	-	-	-	-
80	25	25	25	25	25	25	-	-	-	-	-	-	-	-	-	-
100	25	25	25	25	25	25	30	-	-	-	-	-	-	-	-	-
125	30	30	30	30	30	35	35	35	-	-	-	-	-	-	-	-
150	35	35	35	35	35	40	40	40	40	-	-	-	-	-	-	-
200	45	45	45	45	45	50	50	50	50	50	-	-	-	-	-	-
250	50	55	55	55	55	55	60	60	60	65	65	-	-	-	-	-
300	60	60	60	65	65	65	70	70	70	75	75	75	-	-	-	-
350	70	70	70	75	75	75	80	80	80	85	85	85	90	-	-	-
400	80	80	80	80	85	85	85	90	90	95	95	100	100	100	-	-
450	85	85	90	90	90	95	95	100	100	105	105	110	110	110	110	-
500	95	95	95	100	100	105	105	110	110	115	115	120	120	120	125	125

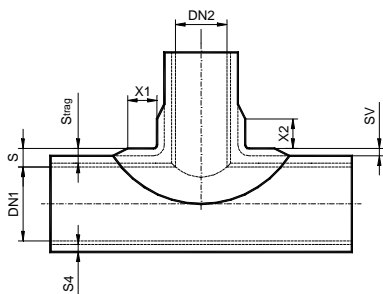

Typ 1

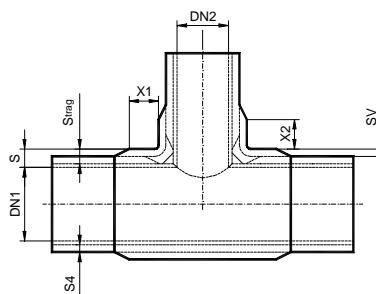

Typ 2

Wall thickness s₄ [mm] according to 2101-WN-en

Laminate thickness s _v																
DN 2 [mm] \ DN 1 [mm]	25	32	40	50	65	80	100	125	150	200	250	300	350	400	450	500
25	2,5	-	-	-	-	-	-	-	-	-	-	-	-	-	-	-
32	2,5	2,5	-	-	-	-	-	-	-	-	-	-	-	-	-	-
40	2,5	2,5	2,5	-	-	-	-	-	-	-	-	-	-	-	-	-
50	2,5	2,6	2,8	2,9	-	-	-	-	-	-	-	-	-	-	-	-
65	2,9	3,1	3,3	3,5	3,7	-	-	-	-	-	-	-	-	-	-	-
80	3,3	3,5	3,8	4,0	4,3	4,5	-	-	-	-	-	-	-	-	-	-
100	3,7	4,0	4,3	4,6	5,0	5,3	5,6	-	-	-	-	-	-	-	-	-
125	4,2	4,6	4,9	5,3	5,8	6,1	6,5	6,9	-	-	-	-	-	-	-	-
150	4,7	5,1	5,5	6,0	6,5	6,9	7,4	7,9	8,2	-	-	-	-	-	-	-
200	5,6	6,1	6,6	7,1	7,8	8,3	9,0	9,6	10,1	10,9	-	-	-	-	-	-
250	6,5	7,0	7,5	8,1	8,9	9,6	10,3	11,1	11,8	12,8	13,5	-	-	-	-	-
300	7,3	7,9	8,4	9,1	9,9	10,7	11,6	12,5	13,3	14,5	15,4	16,1	-	-	-	-
350	8,2	8,7	9,3	10,0	10,9	11,7	12,7	13,8	14,7	16,1	17,2	18,1	18,8	-	-	-
400	9,0	9,5	10,1	10,9	11,9	12,7	13,8	15,0	16,0	17,6	18,9	19,9	20,8	21,4	-	-
450	9,7	10,3	11,0	11,7	12,8	13,7	14,8	16,1	17,2	19,0	20,5	21,6	22,6	23,4	24,1	-
500	10,5	11,1	11,8	12,6	13,6	14,6	15,8	17,2	18,3	20,3	21,9	23,3	24,4	25,3	26,0	27,7

Laminate width X1 and X2																
DN 2 [mm] \ DN 1 [mm]	25	32	40	50	65	80	100	125	150	200	250	300	350	400	450	500
25	25	-	-	-	-	-	-	-	-	-	-	-	-	-	-	-
32	25	25	-	-	-	-	-	-	-	-	-	-	-	-	-	-
40	25	25	25	-	-	-	-	-	-	-	-	-	-	-	-	-
50	25	25	25	25	-	-	-	-	-	-	-	-	-	-	-	-
65	25	25	25	25	25	-	-	-	-	-	-	-	-	-	-	-
80	25	25	25	25	25	30	-	-	-	-	-	-	-	-	-	-
100	30	30	30	30	35	35	35	-	-	-	-	-	-	-	-	-
125	35	35	35	40	40	40	40	40	-	-	-	-	-	-	-	-
150	40	40	45	45	45	45	45	50	50	-	-	-	-	-	-	-
200	55	55	55	55	55	60	60	60	60	65	-	-	-	-	-	-
250	65	65	65	70	70	70	70	75	75	75	80	-	-	-	-	-
300	75	75	80	80	80	80	85	85	90	90	90	95	-	-	-	-
350	85	90	90	90	90	95	95	100	100	105	105	105	110	-	-	-
400	100	100	100	100	105	105	110	110	110	115	120	120	120	120	-	-
450	110	110	110	115	115	115	120	120	125	130	130	135	135	135	135	-
500	120	120	120	125	125	130	130	135	135	140	145	145	150	150	150	150

The below-mentioned elbow dimensions apply to pipe type K. Wall thickness S4 [mm] according to 2101-WN.

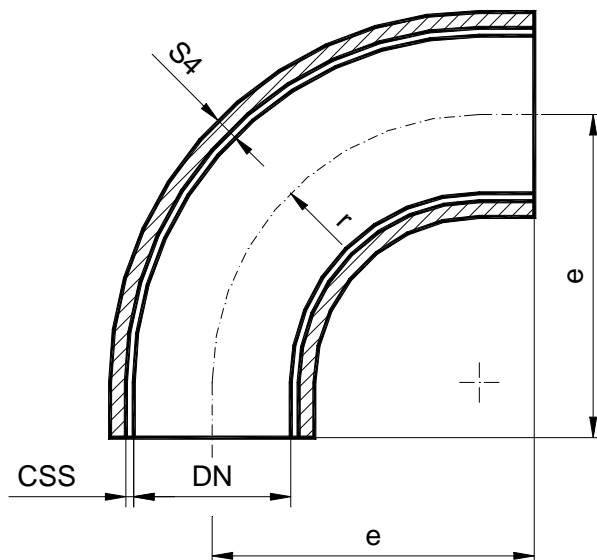

DN [mm]	length e [mm]	Radius r [mm]
25	110	80
32	130	100
40	150	120
50	180	165
65	140	125
80	165	125
100	205	170
125	245	210
150	285	215
200	365	320
250	450	390
300	525	380
350	600	600
400	680	570
450	780	620
500	830	650
600	950	900
712	1070	1000
800	1400	1250
900	1330	1230
1000	1500	1500

Dimensions differ from DIN

Below-mentioned elbow dimensions apply to pipe type K. Wall thickness S4 [mm] according to 2101-WN-en. Flange thickness according to 2210-WN-en alternative to 2209-WN-en and 2312-WN-en. Optionally for one-sided stub flange or for one-sided full faced flange.

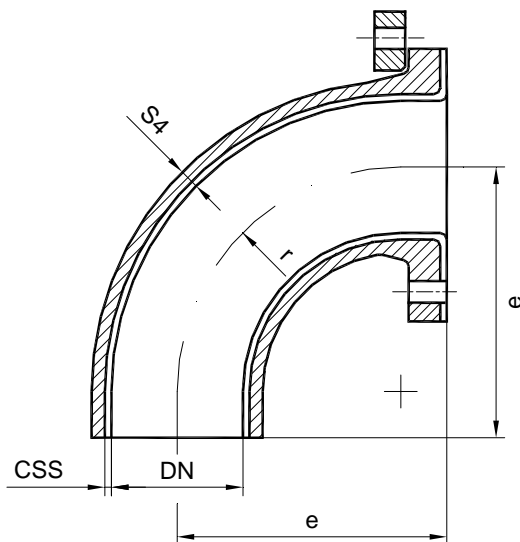

DN [mm]	Length e [mm]	Radius r [mm]
25	110	80
32	130	100
40	150	120
50	180	165
65	140	125
80	165	125
100	205	170
125	245	210
150	285	215
200	365	320
250	450	390
300	525	380
350	600	600
400	680	570
450	780	620
500	830	650
600	950	900
712	1070	1000
800	1400	1250
900	1330	1230
1000	1500	1500
1600	1900	1900

Dimensions differ from DIN

Below-mentioned elbow dimensions apply to pipe type K. Wall thickness S4 [mm] according to 2101-WN-en. Flange thickness according to 2210-WN-en alternative to 2209-WN-en and 2312-WN-en. Optionally for both-sided stub flange or for both-sided full faced flange.

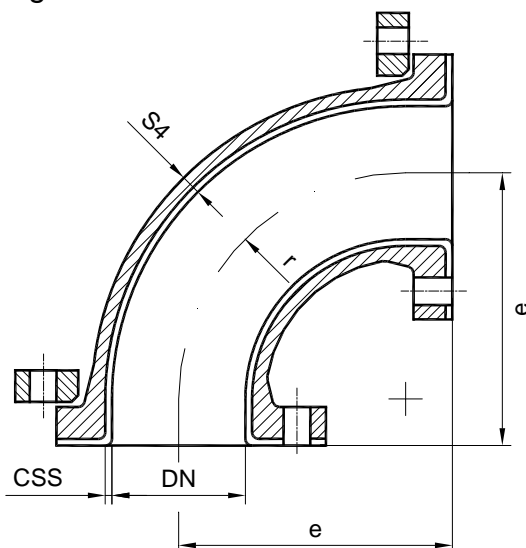

DN [mm]	length e [mm]	Radius r [mm]
25	110	80
32	130	100
40	150	120
50	180	165
65	140	125
80	165	125
100	205	170
125	245	210
150	285	215
200	365	320
250	450	390
300	525	380
350	600	600
400	680	570
450	780	620
500	830	650
600	950	900
712	1070	1000
800	1400	1250
900	1330	1230
1000	1500	1500
1600	1900	1900

Dimensions differ from DIN

Reduction wall thickness bases on the larger diameter wall thickness according to 2101-WN.

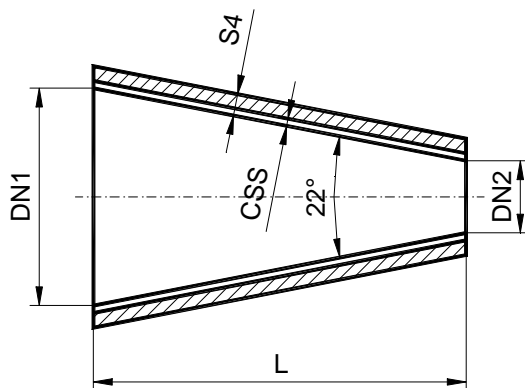

DN1 [mm]	DN2 [mm]	length [mm]
32	25	18
40	25	39
40	32	21
50	25	64
50	32	46
50	40	26
65	32	85
65	40	64
65	50	39
80	40	103
80	50	77
80	65	39
100	50	129
100	65	90
100	80	51
125	65	154
125	80	116
125	100	64
150	80	180
150	100	129
150	125	64

DN1 [mm]	DN2 [mm]	length [mm]
200	100	257
200	125	193
200	150	129
250	125	322
250	150	257
250	200	129
300	150	386
300	200	257
300	250	129
350	200	386
350	250	257
350	300	129
400	250	386
400	300	257
400	350	129
450	300	386
450	350	257
450	400	129
500	350	386
500	400	257
500	450	129
600	400	514
600	450	386
600	500	257

Reduction wall thickness bases on the larger diameter wall thickness according to 2101-WN.

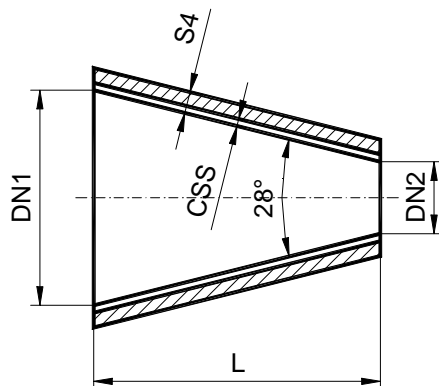

DN1 [mm]	DN2 [mm]	length [mm]
32	25	14
40	25	30
40	32	16
50	25	50
50	32	36
50	40	20
65	32	66
65	40	50
65	50	30
80	40	80
80	50	60
80	65	30
100	50	100
100	65	70
100	80	40
125	65	120
125	80	90
125	100	50
150	80	140
150	100	100
150	125	50
200	100	201
200	125	150
200	150	100
250	125	251
250	150	201
250	200	100

DN1 [mm]	DN2 [mm]	length [mm]
300	150	301
300	200	201
300	250	100
350	200	301
350	250	201
350	300	100
400	250	301
400	300	201
400	350	100
450	300	301
450	350	201
450	400	100
500	350	301
500	400	201
500	450	100
600	400	401
600	450	301
600	500	201
712	450	525
712	500	425
712	600	225
800	500	602
800	600	401
800	712	176
900	600	602
900	712	377
900	800	201
1000	712	578
1000	800	401
1000	900	201

Reduction wall thickness bases on the larger diameter wall thickness according to 2101-WN.

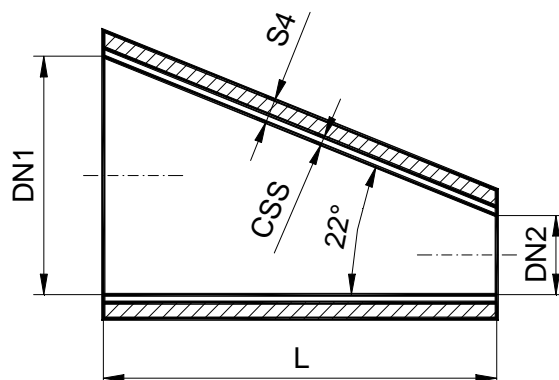

DN1 [mm]	DN2 [mm]	length [mm]
50	40	25
65	40	62
65	50	37
80	40	99
80	50	74
80	65	37
100	50	124
100	65	87
100	80	50
125	65	149
125	80	111
125	100	62
150	80	173
150	100	124
150	125	62
200	100	248
200	125	186
200	150	124
250	125	309
250	150	248
250	200	124
300	150	371
300	200	248
300	250	124

DN1 [mm]	DN2 [mm]	length [mm]
350	200	371
350	250	248
350	300	124
400	250	371
400	300	248
400	350	124
450	300	371
450	350	248
450	400	124
500	350	371
500	400	248
500	450	124
600	400	495
600	450	371
600	500	248
712	450	648
712	500	525
712	600	277
800	500	743
800	600	495
800	712	218
900	600	743
900	712	465
900	800	248
1000	712	713
1000	800	495
1000	900	248

Reduction wall thickness bases on the larger diameter wall thickness according to 2101-WN.

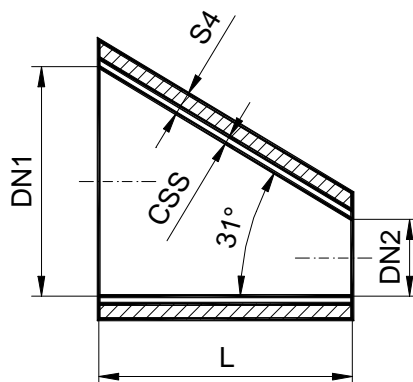

DN1 [mm]	DN2 [mm]	length [mm]
32	25	12
40	25	25
40	32	13
50	25	42
50	32	30
50	40	17
65	32	55
65	40	42
65	50	25
80	40	67
80	50	50
80	65	25

DN1 [mm]	DN2 [mm]	length [mm]
100	50	83
100	65	58
100	80	33
125	65	100
125	80	75
125	100	42
150	80	116
150	100	83
150	125	42
200	100	166
200	125	125
200	150	83
250	125	208
250	150	166
250	200	83

Flange connecting dimensions according to DIN 2501 Part 1, PN10

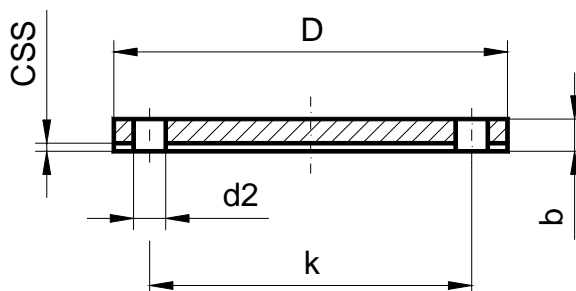

DN	D	K	d2	PN	2,5	4	6	10	16
				Anzahl	[bar]	[bar]	[bar]	[bar]	[bar]
[mm]	[mm]	[mm]	[mm]	Bohrung	b	B	b	b	b
25	115	85	14	4					17
32	140	100	18	4					20
40	150	110	18	4					20
50	165	125	18	4					21
65	185	145	18	4					23
80	200	160	18	8				19	24
100	220	180	18	8				20	24
125	250	210	18	8			17	21	27
150	285	240	22	8			19	23	30
200	340	295	22	8		21	24	27	34
250	395	350	22	12		25	28	34	38
300	445	400	22	12	27	30	34	40	45
350	505	460	22	16	30	34	38	45	52
400	565	515	26	16	34	38	45	51	59
450	615	565	26	20	38	45	49	57	66
500	670	620	26	20	42	48	56	63	74
600	780	725	30	20	48	56	63	76	
712	895	840	30	24	57	66	76	88	
800	1015	950	33	24	63	74	84	98	
900	1115	1050	33	28	72	84	94	110	
1000	1230	1160	36	28	78	94	104	122	

Wall thickness incl. 2,5 mm corrosion barrier.